

Acceleration Sensor



Accelerometer (Acceleration Fiber Bragg Grating Sensor)

Suitable for vibration, security sensing

Application: bridge monitoring, pipeline security monitoring

Acceleration Sensor

Type1:

- Range:5g
- Frequency Range:0-40Hz
- Dimension:72×54×37.5mm

Type2:

- Range:0.5g
- Frequency Range:>100Hz
- Dimension:54×48×24.5mm
- Wavelength:1525 to 1565nm
- Working Tenperature:-30 to 70 degC

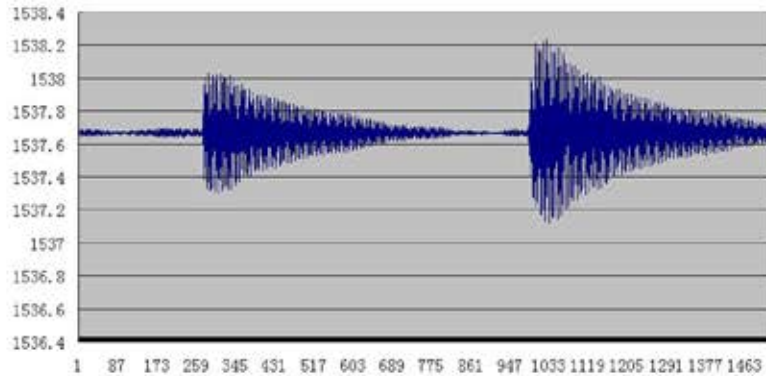

Ordering Code

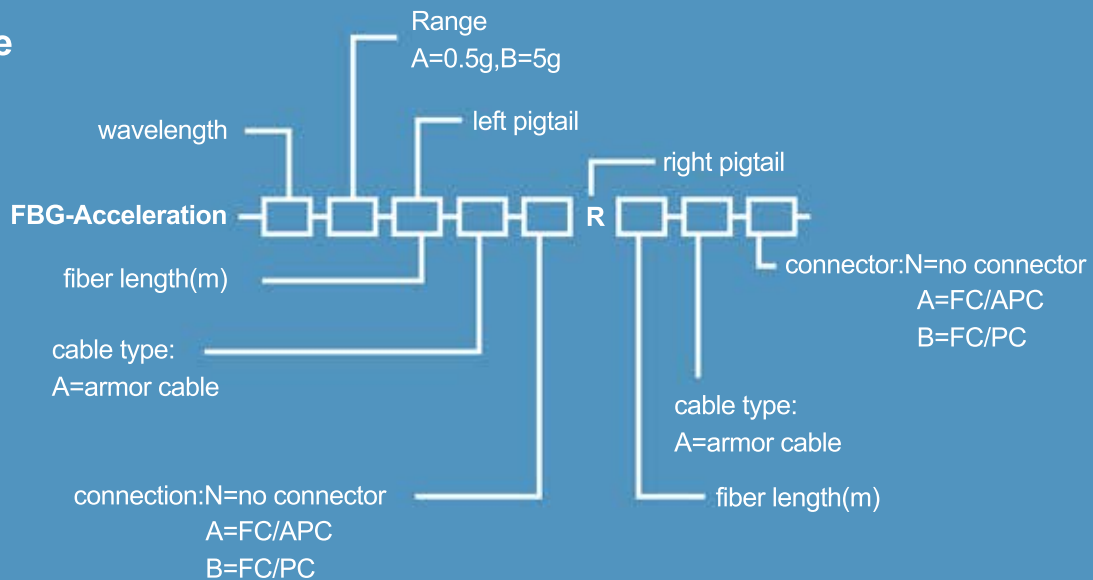

Welltech Instrument Company Limited

Tel 852-23491224

E-mail welltechltd@gmail.com

www.fbg.com.cn

